

1. The following sketch represents a generic open, serial, kinematic-chain.

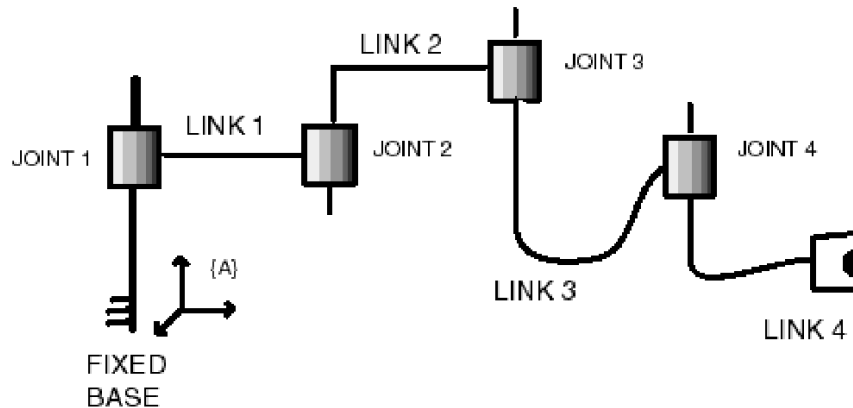

Here each kinematic joint connects two adjacent members. Assume that the relative displacement between adjacent members $i - 1$ and i is described by an operator T_i that is a 4×4 matrix whose elements are computed in a coordinate frame $\{A\}$ fixed to the base of the chain. Now, if each member is displaced in sequence, *starting from the free end*, the displacement operator for the resultant total displacement of the free end will be given by $T_1 T_2 T_3 T_4$. (Note: In this problem you are to use only displacements operators, not coordinate transformations)

However, if the displacements are done in the reverse order, i.e. *starting at the fixed end*, and moving in the sequence 1, 2, 3, 4, then the operators T_2 , T_3 , and T_4 no longer represent the actual displacements.

Determine, in terms of the original T_i :

- The operator for joint 2, when its displacement is done *after* the displacement in joint 1. Let us call this operator T'_2
 - The operator for joint 3 when its displacement follows the displacement in joints 1 and 2 (from part (a)). Let us call this operator T'_3
 - The operator for joint 4 when its displacement follows the displacement in joints 1, 2 and 3 (from part (b)). Let us call this operator T'_4
 - Using your results for parts (a), (b) and (c), show that the resulting displacement operator for the free end is still $T_1 T_2 T_3 T_4$
2. Consider the following RRP manipulator (figure courtesy of J. J. Craig):

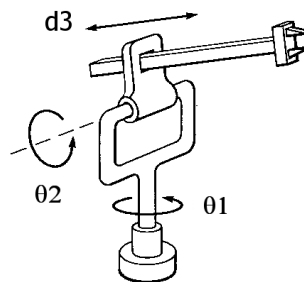

- (a) Draw a schematic of this manipulator, with the axes of frames $\{0\}$ through $\{3\}$ labeled. Also, include the parameters θ_1 , θ_2 , a_2 , and d_3 on your schematic. Assume that in this diagram, the slider bar is parallel to the ground and that this is the configuration where $\theta_1 = 0$, $\theta_2 = 90^\circ$.
- (b) Write down the Denavit-Hartenberg parameters for this manipulator, in the form of a table:

i	a_{i-1}	α_{i-1}	d_i	θ_i
1				
2				
3				

- (c) Derive the forward kinematics for this manipulator — that is, find 0_3T .

3. Consider the following 2RP2R manipulator (figure courtesy of J. J. Craig):

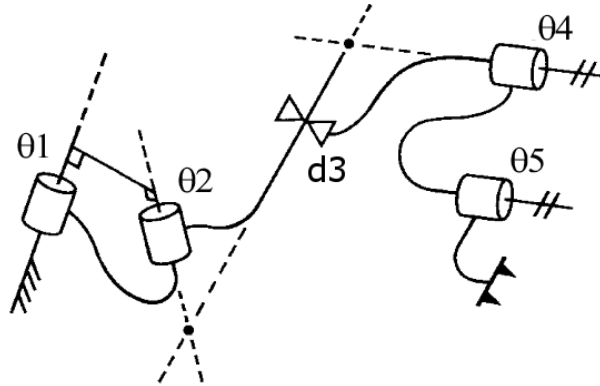

- (a) Draw a schematic of this manipulator, with the axes of frames $\{0\}$ through $\{5\}$ labeled. Include all non-zero Denavit-Hartenberg parameters and the joint variables. Draw your schematic in the position where, as far as possible, the angles θ_i are in their zero positions.
- (b) Write down the Denavit-Hartenberg parameters for this manipulator, in the form of a table:

i	a_{i-1}	α_{i-1}	d_i	θ_i
1				
2				
3				
4				
5				